



OMT3-IE3 315M-2 132kW 400/690V 50Hz , . #

DATASHEET

50Hz |

Frame type:	cast iron	Connection:	Δ/Y
Model:	OMT3-IE3	Run Capacitor:	
Output:	132 kW	Start Capacitor:	
Rated voltage:	400/690V	Rotor voltage:	
Frame:	315 mm	Rotor connection:	
Poles:	2	Rotor current:	
Frequency:	50 Hz	No load current:	
Rated speed:	2980 RPM	Insulation class:	F
Rated current:	222/128,7 A	Temp. rise:	80 K
Locked rotor current(Ia/In):	710%	Service factor:	1
Locked rotor torque(Ma/Mn):	180%	Duty:	S1
Breakdown torque(Ma/Mn):	230%	Amb. temp.:	-20~40 °C
Mounting:	B3	Altitude:	1000 m
Noise level:	92 dB	Protection:	IP55
Approx. weight:	948 kg	Cooling:	IC411
Mom. of inertia:	2,110695 kg/m ²	Vibration:	2,8 mm/s
Slip:	0,7%	Dir. rotation:	BOTH
Rated torque:	423 Nm	Starting method:	DIRECT ON LINE
		Coupling:	DIRECT
		Load type:	PARABOLIC CURVE

PERFORMANCE

Output	50%	75%	100%
Efficiency(%):	94,6	95,5	95,4
Power factor:			0,9

BEARING

	NDE	DE
Bearing	6317 C3	6317 C3
Regreasing int(h):	2000	2000
Grease amount(g):	38	38
Grease polyrexEM:	Caltex SRI-2	Caltex SRI-2

STANDARDS

Specification:	IEC60034-1/GB755
Test:	IEC60034-2/GB/T1032
Noise	IEC60034-9/GB10069.3
Vibration:	IEC60034-14/GB10068

ACCESSORIES

PTC 150°C

There may be differences between rating plate and calculated values

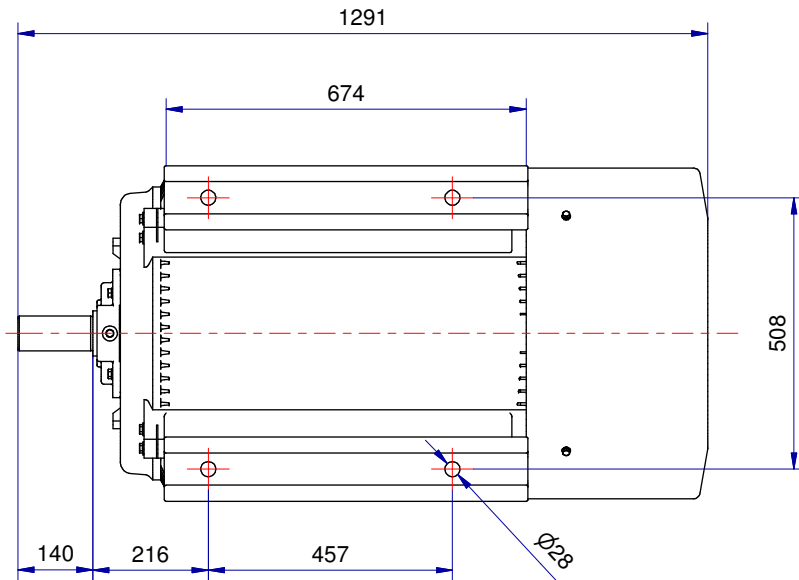
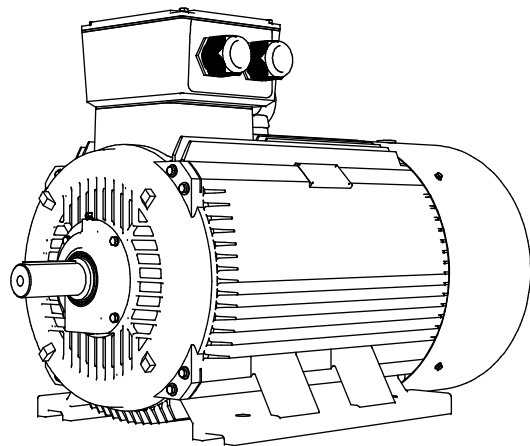
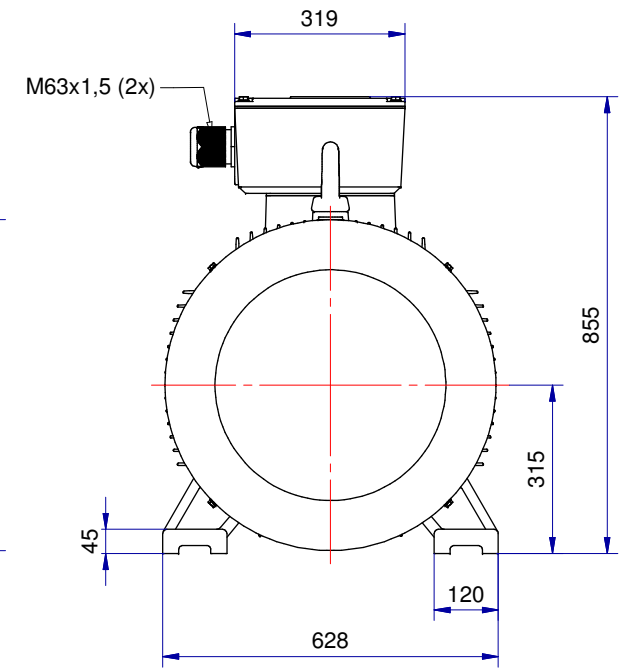
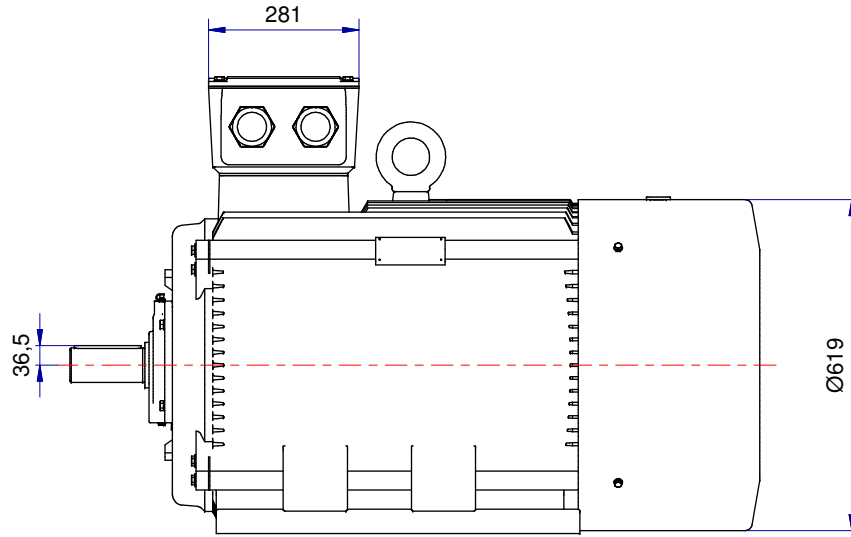
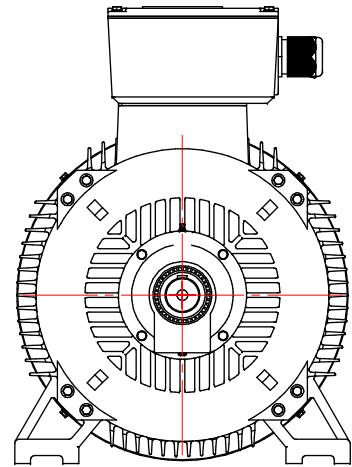

Shaft detail

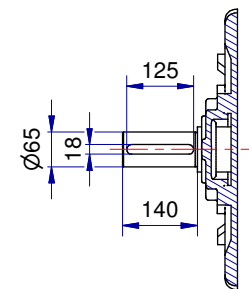

03-IP55-Cast Iron-IE3-315M B3-2